

ANSYS CFX

Powerful Computational Fluid Dynamics Software for Process and Product Design Optimization

For more than 20 years, companies around the world have trusted ANSYS® CFX® technology to provide reliable and powerful computational fluid dynamics (CFD) solutions. ANSYS CFX combines advanced solver technology with a modern user interface and an adaptive architecture to make CFD accessible to both designers with general engineering knowledge and fluid dynamics specialists requiring in-depth model control and options. It is used in a vast array of industries to provide detailed insight into equipment and processes that increase efficiency, improve product longevity and optimize processes.

ANSYS CFX and the ANSYS Workbench Environment

ANSYS CFX software is fully integrated into the ANSYS® Workbench™ environment, the framework for the full suite of engineering simulation solutions from ANSYS. Its adaptive architecture enables users to easily set up anything from standard fluid flow analyses to complex interacting systems with simple drag-and-drop operations. Users can easily assess performance at multiple design points or compare several alternative designs. Within the ANSYS Workbench environment, applications from multiple simulation disciplines can access tools common to all, such as geometry and meshing tools.

Geometry: ANSYS® DesignModeler™ software is specifically designed for the creation and preparation of geometry for simulation. Its easy-to-use, fully parametric environment with direct, bidirectional links to all leading CAD packages acts as the geometry portal for all ANSYS products to provide a consistent geometry source for all engineering simulations.

Meshing: Providing accurate CFD results requires superior meshing technology. ANSYS Meshing provides a multitude of meshing technologies in a single application to allow users to select the best option on a part-by-part basis. ANSYS® ICEM CFD™ meshing tools also are available and include unlimited mesh editing capabilities as well as structured hexahedral meshing.

CFD Pre-Processing in CFX-Pre

The ANSYS CFX physics pre-processor is a modern and intuitive interface for the setup of CFD analyses. In addition to a general mode of operation, predefined wizards are available to guide users through the setup of common fluid flow simulations. A powerful expression language gives users the ability to customize their problem definition in numerous ways, such as with complex boundary conditions, proprietary material models or additional transport equations. The adaptive architecture of CFX-Pre even allows users to create their own custom GUI panels to standardize input for selected applications, and thereby ensure adherence to established best practices

Industry Solutions



Vortex structures in a four-stroke engine just after injection of fuel and intake valve opening
Courtesy of BMW Group.

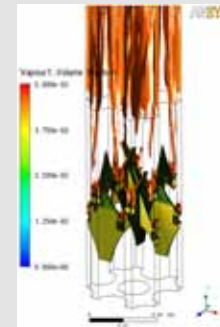

Nucleate boiling downstream of spacers in a fuel rod bundle assembly
Courtesy of Dr. E. Krepper, FZ Dresden.

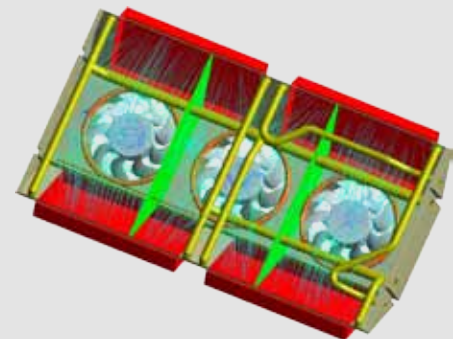

Bottom of the cooling system showing obstructions
Courtesy of Voith Turbo.

Industry Solutions

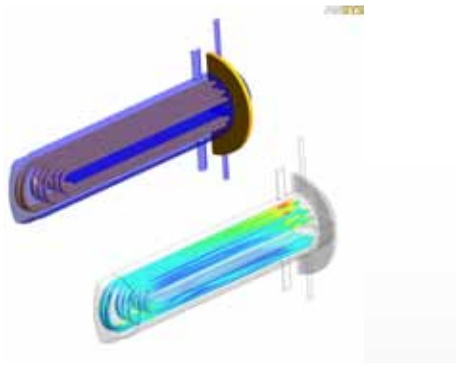

Prediction of heat transfer distribution in a shell and tube heat exchanger

Courtesy of Flow Dynamics Hellas & Proodos Boilers.

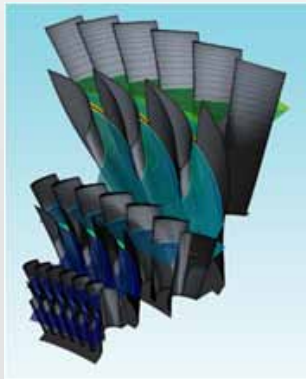

Prediction of wetness dispersion under non-equilibrium conditions for quantification of thermo-dynamic performance in a low-pressure steam turbine

Courtesy Siemens AG.



Particle tracking functionality used to simulate the fertilization of kiwifruit by blowing pre-collected pollen onto the flowers

Courtesy University of Canterbury.

The ANSYS CFX Solver

At the heart of ANSYS CFX software is its advanced solver technology using coupled algebraic multigrid, the key to achieving reliable and accurate solutions quickly and robustly. Its engineered scalability ensures a linear increase in CPU time with problem size and parallel performance that is second to none. Users can follow convergence progress and dynamically monitor numerical and physical solution quantities. Solver parameters, boundary conditions and other parameters can be adjusted 'on the fly,' without stopping the solver. The ANSYS CFX solver uses second order numerics by default, ensuring users always get the most accurate predictions possible.

All simulations, whether for rotating machinery, multiphase flows, combustion or any other physical model, benefit enormously from the coupled solver technology in ANSYS CFX software to achieve robust and scalable flow solutions.

Parallelization: The ANSYS CFX solver was designed from the ground up for maximum parallel efficiency. This deep-rooted characteristic has become all the more essential since the advent of multicore processors and cluster computing. With impressive CPU and memory scaling ANSYS CFX software is inherently prepared for the continued evolution of computing power. All physical models in the ANSYS CFX solver work in parallel, without exception.

Physical Models: The fidelity of simulation is linked directly to the choice of physical models available. ANSYS CFX software contains unequalled breadth and unparalleled depth of physical models to satisfy the needs of a wide variety of industrial applications. More importantly, a complete feature matrix ensures maximum interaction among physical models with all element types and across all grid interface connection types to allow comprehensive multiphysics simulations.

The following are some of the most important physical models available in ANSYS CFX software.

Turbulence: The vast majority of industrial flows are turbulent. Therefore, ANSYS CFX software has always placed special emphasis on providing and developing state-of-the-art turbulence models to capture the effects of turbulence efficiently and accurately. In addition to all common RANS models — such as $k-\epsilon$, $k-\omega$, SST and Reynolds-Stress models — and scale-resolving LES and DES models, ANSYS CFX software delivers numerous significant turbulence modeling innovations. These innovations include SST model extensions to capture effects like streamline curvature, a predictive laminar-to-turbulent transition model (the Menter-Langtry $\gamma-\theta$ model™) and the novel scale-resolving Scale-Adaptive Simulation™ (SAS) model for flows in which steady-state turbulence models are insufficient.

Rotating Machinery: ANSYS CFX software has continuously shown leadership in CFD simulation for rotating machinery. It is a leader in a field where the demands in terms of accuracy, speed and robustness are among the very highest. From a full suite of models to capture the interaction between rotating and stationary components, to tailored turbomachinery pre- and post-processing environments, ANSYS CFX software completely satisfies the needs of turbomachinery fluid dynamics analysts. It is further complemented by ANSYS® BladeModeler™ and ANSYS® TurboGrid™, geometry and mesh generation tools made expressly to meet the needs of turbomachinery designers and analysts.

Industry Solutions

Multiphase: More than two decades of experience in multiphase modeling is incorporated into ANSYS CFX software, to allow the simulation of multiple fluid streams, bubbles, droplets, particles and free surface flows. The Lagrangian transport model allows the solution of one or more discrete particle or droplet phases within a continuous fluid phase. Break-up models are available to describe both the initial fluid atomization and further fragmentation due to the action of external forces. Further options include an efficient statistical particle-particle collision model and a quasi-static wall film model. The Eulerian multiphase model incorporates a wealth of options to capture the exchange of momentum, energy and mass, including numerous drag and non-drag force models as well as robust models for phase change due to cavitation, evaporation, condensation and boiling. The multiple size group (MUSIG) model is available to simulate the breakup and coalescence of disperse phases in poly-dispersed multi-phase flows.

Heat Transfer and Radiation: Beyond solving the convective transport of energy by fluid flow, ANSYS CFX software includes a conjugate heat transfer (CHT) capability to solve the thermal conduction in solids. It also incorporates a wealth of models to capture all types of radiative heat exchange in and between fluids and solids, whether these are fully or semitransparent to radiation or opaque.

Combustion: Whether simulating combustion design in gas turbines, automotive engines or coal-fired furnaces, or assessing fire safety in and around buildings and other structures, ANSYS CFX software provides a rich framework to model chemical reactions and combustion associated with fluid flow. Combustion models are provided for anything from laminar to turbulent flows, fast to slow chemical kinetics and non- to partially or fully pre-mixed reactants. A rich library of predefined chemical reactions that can be easily edited and extended by users, as well as the integration of the flamelet library generator ANSYS CFX-RIF for detailed chemistry tables, provides a complete range of options for all situations. These are rounded out with models for auto and spark ignition, pollutant formation (NO_x, soot), residual exhaust gases, knock, wall quenching, flame extinction and more.

Fluid Structure Interaction (FSI): ANSYS combines the specialized capabilities and technology of its leading fluid dynamics and structural mechanics software to provide the most advanced capability for the simulation of the interaction between fluids and solids. Both one-way and two-way FSI simulations are possible, from problem setup to post-processing, all within the ANSYS Workbench environment. The native two-way connection to structural analysis technologies from ANSYS allows users to capture even the most complex FSI problems without the need to purchase, administer or configure third-party coupling software.

Moving Mesh, Remeshing and Immersed Solids: Beyond the powerful range of options for capturing FSI together with ANSYS structural analysis technologies many additional options exist directly within ANSYS CFX software to model the effect of solid motion on fluid flow. Mesh deformation technology used in FSI simulations to allow large ranges of motion with a fixed mesh topology can be combined with external remeshing to capture even the most complex geometry movement. This motion can be either prescribed, such as the valve and piston motion in an internal

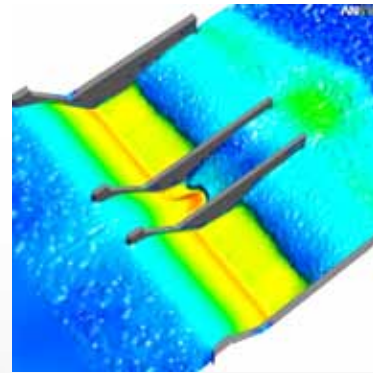

Flow velocities on the free surface water flow across a dam with a sluice, showing hydraulic jump just past the base

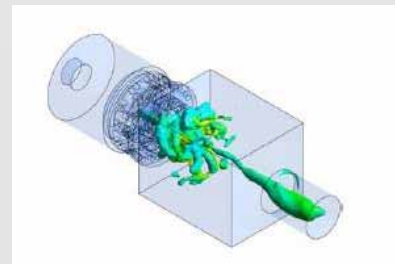

A precessing vortex core colored by axial velocity in an SAS simulation of a combustion chamber
Courtesy of German Aerospace Center (DLR) Institute of Combustion Technology.

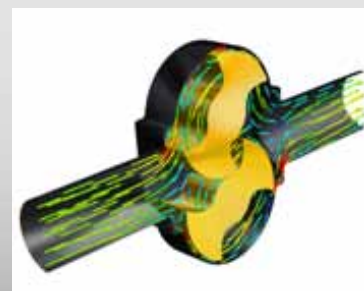

The flow through a screw pump simulated using the immersed solid technology to capture the motion of the rotors

Industry Solutions

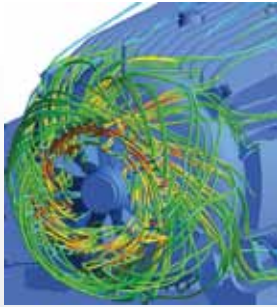

Cooling air flow predictions to optimize heat transfer around electric motor

Courtesy WEG Motors.

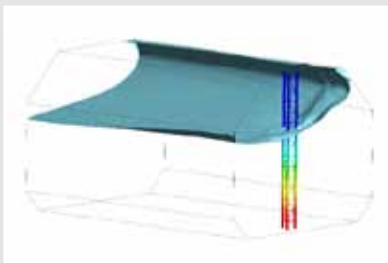

Simulation of sloshing in partially filled tanks on marine vessels, used to predict structural loads and changes in vessel behavior due to the sloshing of the fluid



Evolution of the free surface of oil in a reciprocating compressor

Courtesy of Embraco.

combustion engine, or can be an implicit result of the solution using the built-in six-degrees-of-freedom rigid body solver available in ANSYS CFX software. The immersed solids method is an additional option that allows unlimited motion of solid objects through fluid to be defined without any need for mesh deformation. The collection of strategies available means that ANSYS CFX users have options for virtually every conceivable geometry motion.

Post-Processing with ANSYS CFD-Post

Complete and powerful post-processing capabilities for ANSYS CFX results are provided with ANSYS CFD-Post for both graphical and quantitative analysis. Together with full scripting and automation, including report generation, ANSYS CFD-Post ensures users get the most out of their CFD simulations.

Summary

The superior performance of ANSYS CFX software is not based on any single product feature. It is the combination of proven, leading-edge technology in all elements of the software that provides the accuracy, reliability, speed and flexibility that companies trust to make them successful. Integration into the ANSYS Workbench environment opens the door to even more applications and new levels of efficiency in engineering simulation.

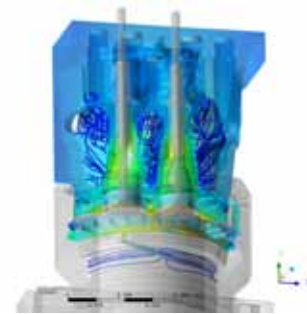
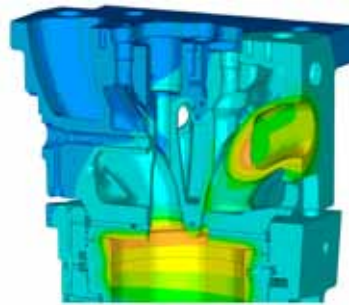

The predicted flow of coolant in a marine diesel engine is used to get more accurate assessment of temperatures in the cylinder head using ANSYS fluid-structure interaction capabilities

Courtesy of MAN Diesel SE.

ANSYS[®]
www.ansys.com

ANSYS, Inc.
Southpointe
275 Technology Drive
Canonsburg, PA 15317
U.S.A.
724.746.3304
ansysinfo@ansys.com

Toll Free U.S.A./Canada:
1.866.267.9724
Toll Free Mexico:
001.866.267.9724
Europe:
44.870.010.4456
eu.sales@ansys.com



ANSYS, ANSYS Workbench, HPSS, AUTODYN, CFX, FLUENT and any and all ANSYS, Inc. brand, product, service and feature names, logos and slogans are registered trademarks or trademarks of ANSYS, Inc. or its subsidiaries in the United States or other countries. ICEM CFD is a trademark used under license. All other brand, product, service and feature names or trademarks are the property of their respective owners.